

Transfer or duplication of this document as well as the utilization or communication of its contents are prohibited unless explicit authorization is granted. Violations will be liable for compensation. All rights reserved for patent, utility model or designs registrations. 未经许可复制或传播本文件内容, 复制或传播本文件内容, 未经授权, 公司将保留追究法律责任。本公司保留所有权利。

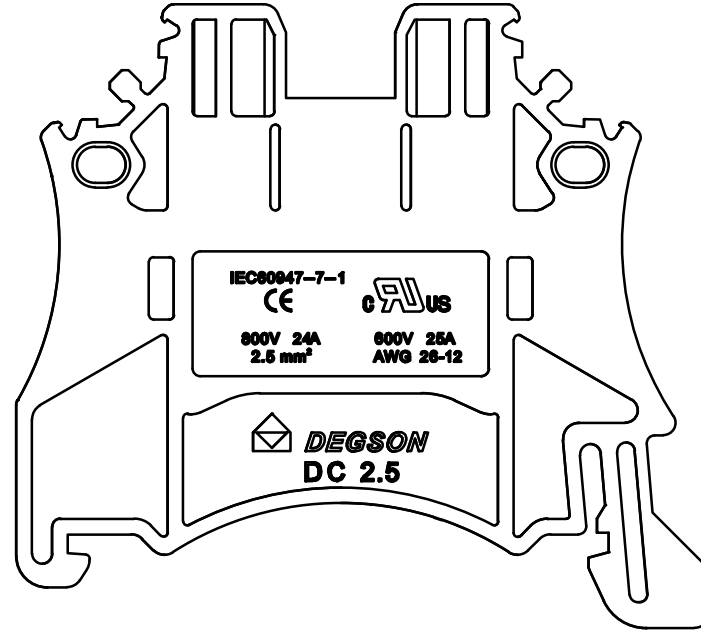
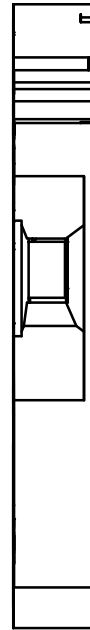
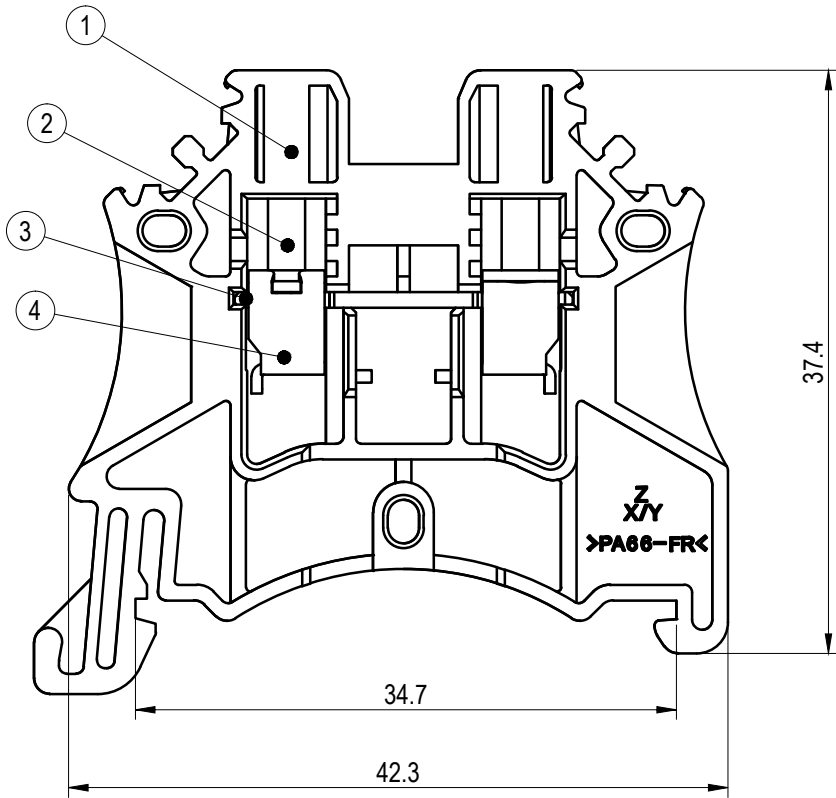
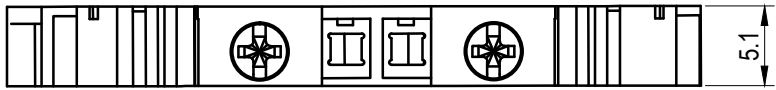

未注公差/General tolerances(mm)													0.1/10	
0	>3	>6	>10	>18	>30	>50	>80	>120	>180	>250	>315	>400		>500
~3	~6	~10	~18	~30	~50	~80	~120	~180	~250	~315	~400	~500	>500	
±0.12	±0.18	±0.22	±0.26	±0.31	±0.37	±0.57	±0.80	±0.93	±1.05	±1.15	±1.60	±2.20	±2.50	±2*

UL 标准/UL Standard:	B	C	D
额定电压/电流/Rated Voltage(V)/Current(A)	600/25	600/25	600/5
IEC 标准/IEC Standard:			
过压类别/Overvoltage Category/污染等级/Pollution Degree	III/3	III/2	II/2
额定电压/电流/Rated Voltage(V)/Current(A)	800/24	/	/
额定脉冲电压(KV)/Rate Impulse Voltage(KV)	8	/	/
螺丝扭矩/Torque Tightening(N·m/Lb.in)	M2.5, 0.4/3.54		
线径范围(硬线和软线)/Wire Range(rigid and flexible)(AWG/mm²)	26~12 / 0.2~2.5		
间距/Pitch(mm)/线数范围/Poles	5.1/01P		
剥线长度/Stripping length(mm)	8~9		
使用温度范围/Operating temperature(°C)	-40~+105		
符合RoHS环保要求/Conform to RoHS	Yes		

4	Cage	Steel	Zn Plated
3	Current Carrier	Copper	Sn Plated
2	Screw	Steel	Zn Plated
1	Housing	PA66	UL94V-0
ITEM	NAME OF PART	MATERIAL	NOTES

		MATERIAL: /		SURFACE/COLOR: /	
APPD: PengM 2022.08.17		MAT NO./REV: /		MAT STATUS: /	
CHKD: GaoWG 2022.08.17		NAME			
DRFT: XieXD 2022.08.17		DC2.5-01P-1Y-12A(H)			
DRAWING NO. /		TYPE		DRAWING STATUS	
A4		CUSTOMER DRAWING		/	
SCALE		SHEET			
2:1		1/1			

REV	ECN	DESCRIPTION	DRFT	DATE
00	/	/	XieXD	2022.08.17